

Ball Valves

Fittings
Valves
Regulators
Filters
Tubing
Integrated Systems
Other Products
Technical Information

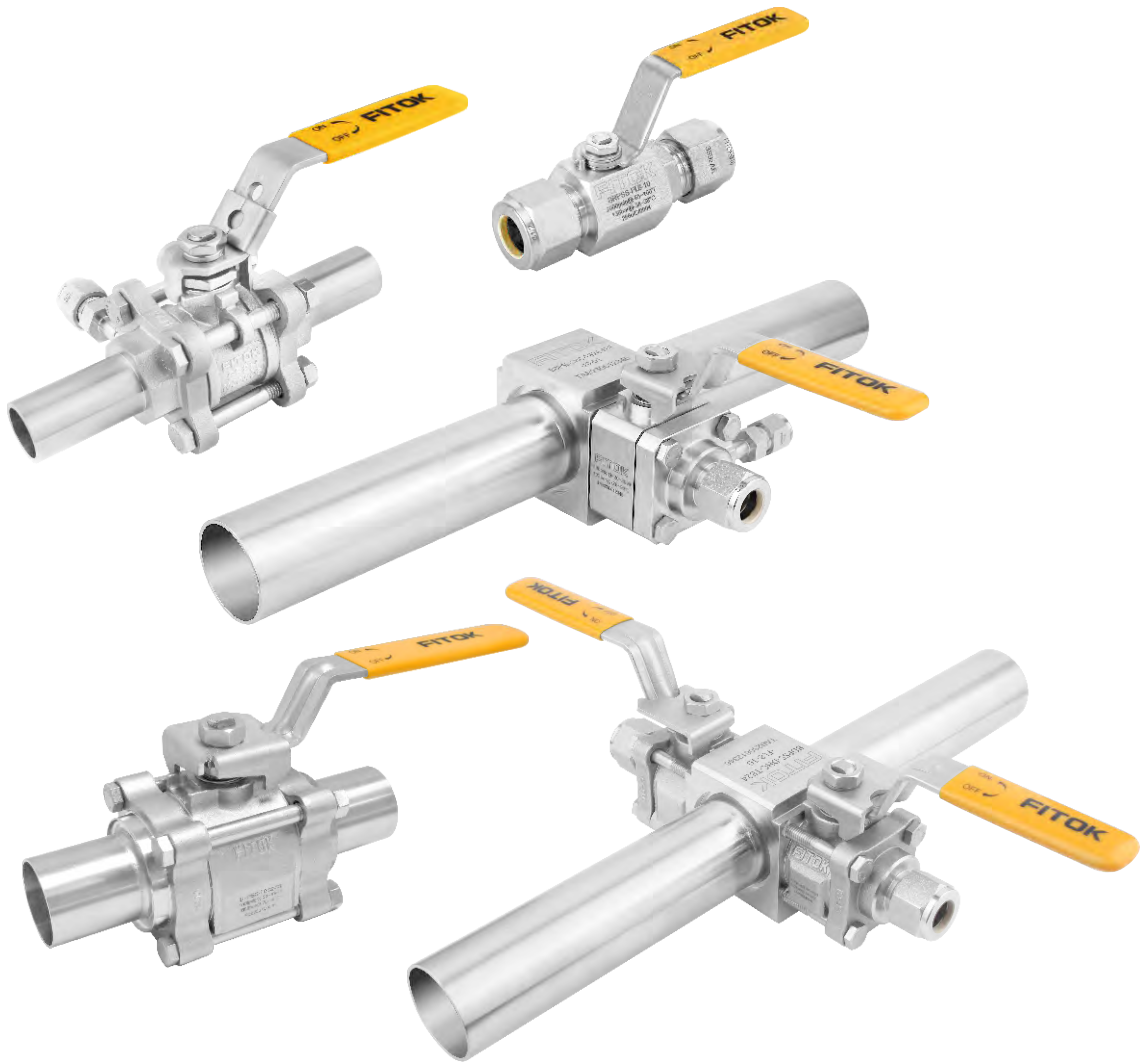

Contents

3-Piece High Purity Ball Valves BGP Series	V-105
3-Piece High Purity Ball Valves BHP Series	V-110
Distribution Block Valves BDP Series	V-116
Hex Bar Stock High Purity Ball Valves BRP Series	V-123

Fittings

Valves

Regulators

Filters

Tubing

Integrated
SystemsOther
ProductsTechnical
Information

3-Piece High Purity Ball Valves

BGP Series



Introduction

BGP series 3-piece high purity ball valves are designed to meet the requirements of degreasing, low working pressure, high flow rate and bi-directional flow for the clean dry air (CDA) and bulk gas distribution line, which are widely used in specialty gas, semiconductor and chemical industries.

Features

- ⦿ Working pressure up to: 1000 psig (69.0 bar)
- ⦿ Working temperature: -20 °F to 450 °F (-28 °C to 232 °C)
- ⦿ Orifice sizes: 0.18" (4.6 mm) to 1.5" (38.1 mm)
- ⦿ Factory tested for leaks with nitrogen or compressed air at rated working pressure, with optional helium leak testing to helium leak rate $\leq 1 \times 10^{-8}$ std·cm³/s

Pressure vs. Temperature

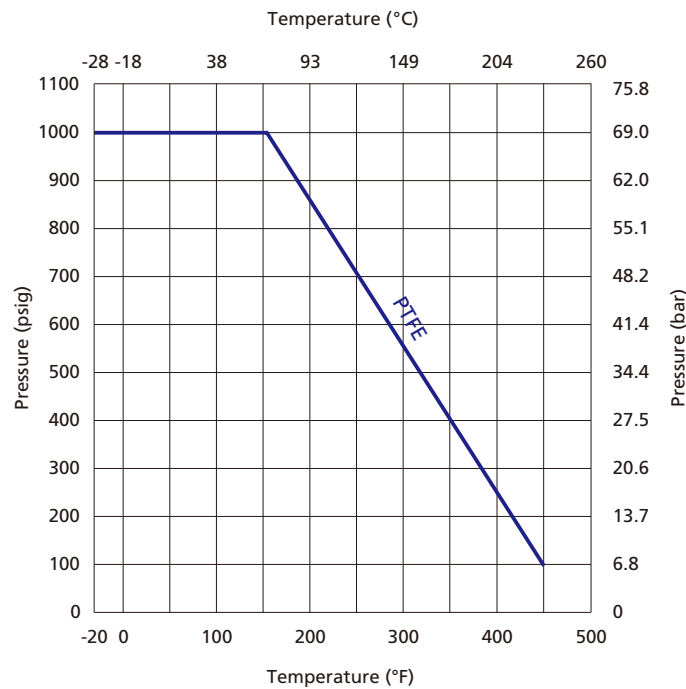

Note: The temperature and pressure rating is based on valves of standard materials.

Fittings
 Valves
 Regulators
 Filters
 Tubing
 Integrated Systems
 Other Products
 Technical Information

Process Specification

Item	Special Cleaning and Packaging Process (FC-02)	Ultra High Purity Process (FC-03)
Material	CF8M, CF3M	CF3M
Flow Path Surface Roughness	Ra 25 µin. (0.6 µm)	Ra 10 µin. (0.25 µm)
Process	Machined	Electropolished
Lubrication	Components in contact with the medium are treated with special lubricants that are oxygen-compatible	

Major Materials of Construction

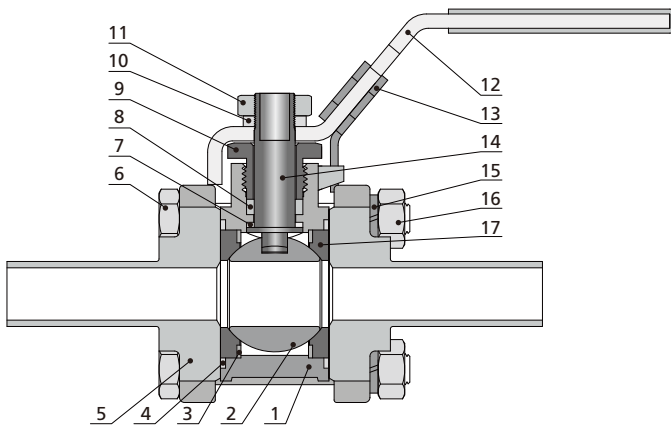

Item	Component	Material/Specification	
1	<i>Body</i>	<i>CF8M/A351</i>	<i>CF3M/A351</i>
2	<i>Ball</i>	<i>316 SS/A479</i>	<i>316L SS/A479</i>
3	<i>Support Ring</i>	<i>316 SS/A240</i>	<i>316L SS/A240</i>
4	<i>Side Seal</i>	<i>PTFE/D1710</i>	
5	<i>End Cap</i>	<i>CF3M/A351</i>	
6	Body Bolt	Stainless Steel	
7	<i>Stem Bearing</i>	<i>PTFE/D1710</i>	
8	<i>Stem Packing</i>	<i>PTFE/D1710</i>	
9	<i>Packing Gland</i>	<i>304 SS/A479</i>	
10	Gasket	Stainless Steel	
11	Stem Nut	Stainless Steel	
12	Handle	<i>304 SS/A240 (with PVC Sleeve)</i>	
13	Lock Block	<i>304 SS/A240</i>	
14	<i>Stem</i>	<i>316 SS/A479</i>	<i>316L SS/A479</i>
15	Standard Spring Gasket	Stainless Steel	
16	Hex Nut	Stainless Steel	
17	<i>Seat</i>	<i>PTFE/D1710</i>	

Note: Components in contact with the media are listed in italics. For other materials, please contact FITOK Group or our authorized distributors.

Dimensions

Dimensions in in. (mm) are for reference only and subject to change.

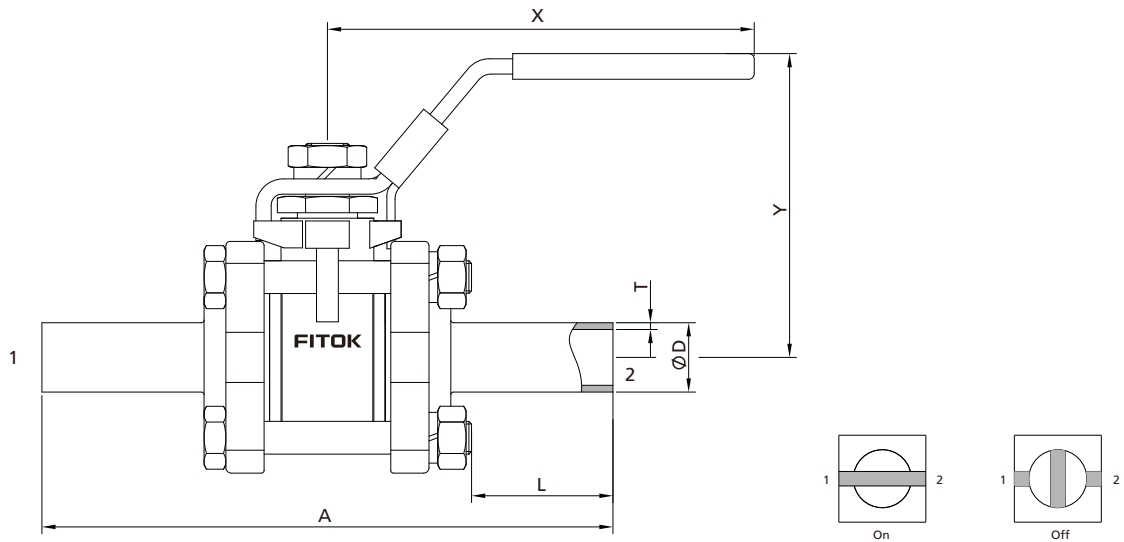

Ordering Information	Connection Type and Size	Orifice in. (mm)	Cv	Dimensions, in. (mm)					
				A	L	D	T	X	Y
BGP□□-TB4-05	1/4" × 0.035" Fractional Extended Tube Plain Butt Weld	0.18 (4.6)	1.1	3.30 (83.3)	0.81 (20.5)	0.25 (6.35)	0.035 (0.89)	2.69 (68.3)	1.46 (37.0)
BGP□□-FL4-05	1/4" FITOK Tube Fittings	0.19 (4.8)	1.2	2.63 (66.8)	—	—	—		
BGP□□-ML6-05	6 mm FITOK Tube Fittings			3.30 (83.3)	0.81 (20.5)	0.375 (9.53)	0.035 (0.89)		
BGP□□-ML8-05	8 mm FITOK Tube Fittings								
BGP□□-TB6-07	3/8" × 0.035" Fractional Extended Tube Plain Butt Weld	0.28 (7.1)	3.8	3.30 (83.3)	0.81 (20.5)	0.375 (9.53)	0.035 (0.89)	2.69 (68.3)	1.46 (37.0)
BGP□□-FL6-07	3/8" FITOK Tube Fittings			2.63 (66.8)	—	—	—		
BGP□□-ML10-07	10 mm FITOK Tube Fittings								
BGP□□-TB8-11	1/2" × 0.049" Fractional Extended Tube Plain Butt Weld	0.40 (10.21)	7.2	4.12 (104.6)	0.93 (23.5)	0.50 (12.7)	0.049 (1.24)	3.94 (100.0)	2.19 (55.7)
BGP□□-FL8-11	1/2" FITOK Tube Fittings	0.42 (10.6)	7.5	4.04 (103.0)	—	—	—		
BGP□□-ML12-11	12 mm FITOK Tube Fittings			5.12 (130.0)	1.26 (32)	0.75 (19.05)	0.065 (1.65)		
BGP□□-ML14-11	14 mm FITOK Tube Fittings								
BGP□□-FL10-13	5/8" FITOK Tube Fittings	0.5 (12.7)	11.3	—	—	—	—	3.94 (100.0)	2.26 (57.5)
BGP□□-TB12-15	3/4" × 0.065" Fractional Extended Tube Plain Butt Weld	0.55 (14.0)	13	5.12 (130.0)	1.26 (32)	0.75 (19.05)	0.065 (1.65)		
BGP□□-FL12-15	3/4" FITOK Tube Fittings			4.04 (103.0)	—	—	—		
BGP□□-ML18-15	18 mm FITOK Tube Fittings								
BGP□□-TB16-20	1" × 0.065" Fractional Extended Tube Plain Butt Weld	0.79 (20.0)	34	6.3 (160.0)	1.67 (42.5)	1.00 (25.4)	0.065 (1.65)	5.18 (131.5)	2.66 (67.5)
BGP□□-FL16-20	1" FITOK Tube Fittings			5.12 (130.0)	—	—	—		
BGP□□-ML22-20	22 mm FITOK Tube Fittings								
BGP□□-ML25-20	25 mm FITOK Tube Fittings								
BGP□□-TB24-32	1 1/2" × 0.065" Fractional Extended Tube Plain Butt Weld	1.25 (31.8)	100	7.81 (198.3)	2.07 (52.6)	1.50 (38.1)	0.065 (1.65)	9.14 (232)	4.03 (102)
BGP□□-TB32-38	2" × 0.065" Fractional Extended Tube Plain Butt Weld	1.50 (38.1)	130	8.59 (218.1)	2.04 (51.8)	2.00 (50.8)		9.14 (232)	4.16 (103)

- Sizes and types listed are standard. Other sizes and types are available upon request, please contact FITOK Group or our authorized distributors.
- Connection tube length can be specified, such as BGPSS-TB4-05, if L=30 mm is required, the part number should be changed to BGPSS-TB4 × L30-05.

Locking Device

- ⦿ Lock BGP series valves, locking hole diameters of: valves with orifice 05 or 07 are 0.185 in. (4.7 mm); valves with orifice 11, 13, 15, or 20 are 0.22 in. (5.7 mm); valves with orifice 32, 38 are 0.394 in. (10 mm)
- ⦿ To order a ball valve with locking device, please refer to the "Ordering Number Description" and add -L to the valve ordering number
Example: BGPSS-FL8-11-L

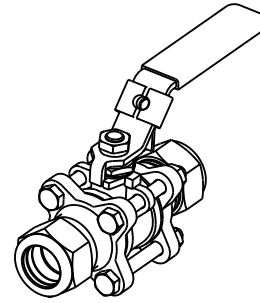

Diagram of Ball Valves with Locking Device

Low Dead Space Inserts

- ⦿ Reduce fluid entrapment around the ball, stem, and seat when the valve is open or closed
- ⦿ To order a ball valve with low dead space insert, please add -RZ to the valve ordering number
Example: BGPSS-FL4-05-RZ



Ordering Number Description

BGPSS - TB4 - TB6 - 05 - I L - U1D2 - RZ - AR2F3

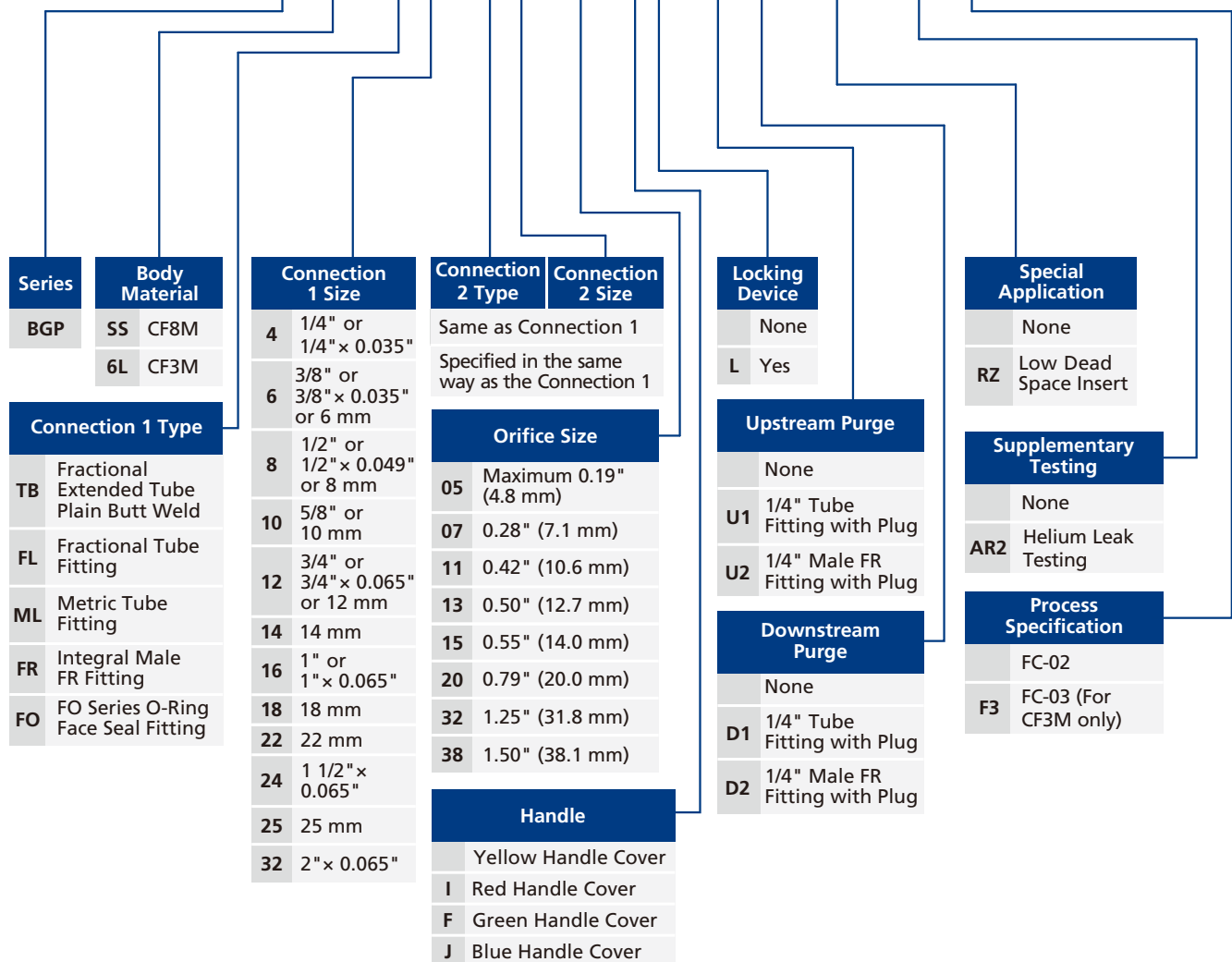

Note: "Ordering Number Description" is a reference to understand the combination rules of FITOK product part number. Not all combinations are available, Should you have any questions, please contact FITOK Group or our authorized distributors.

- Fittings
- Valves
- Regulators
- Filters
- Tubing
- Integrated Systems
- Other Products
- Technical Information

3-Piece High Purity Ball Valves

BHP Series



Introduction

BHP Series 3-piece high purity ball valves are designed to meet the requirements of degreasing, high working pressure, high flow rate and bi-directional flow for the clean dry air (CDA) and bulk gas distribution line, which are widely used in specialty gas, semiconductor and chemical industries.

Features

- ⦿ Working pressure up to: 3000 psig (207 bar)
- ⦿ Working temperature: -20 °F to 450 °F (-28 °C to 232 °C)
- ⦿ Orifice sizes: 0.18" (4.6 mm) to 1.5" (38.1 mm)
- ⦿ Factory tested for leaks with nitrogen or compressed air at rated working pressure, with optional helium leak testing to helium leak rate $\leq 1 \times 10^{-8}$ std-cm³/s

Pressure vs. Temperature

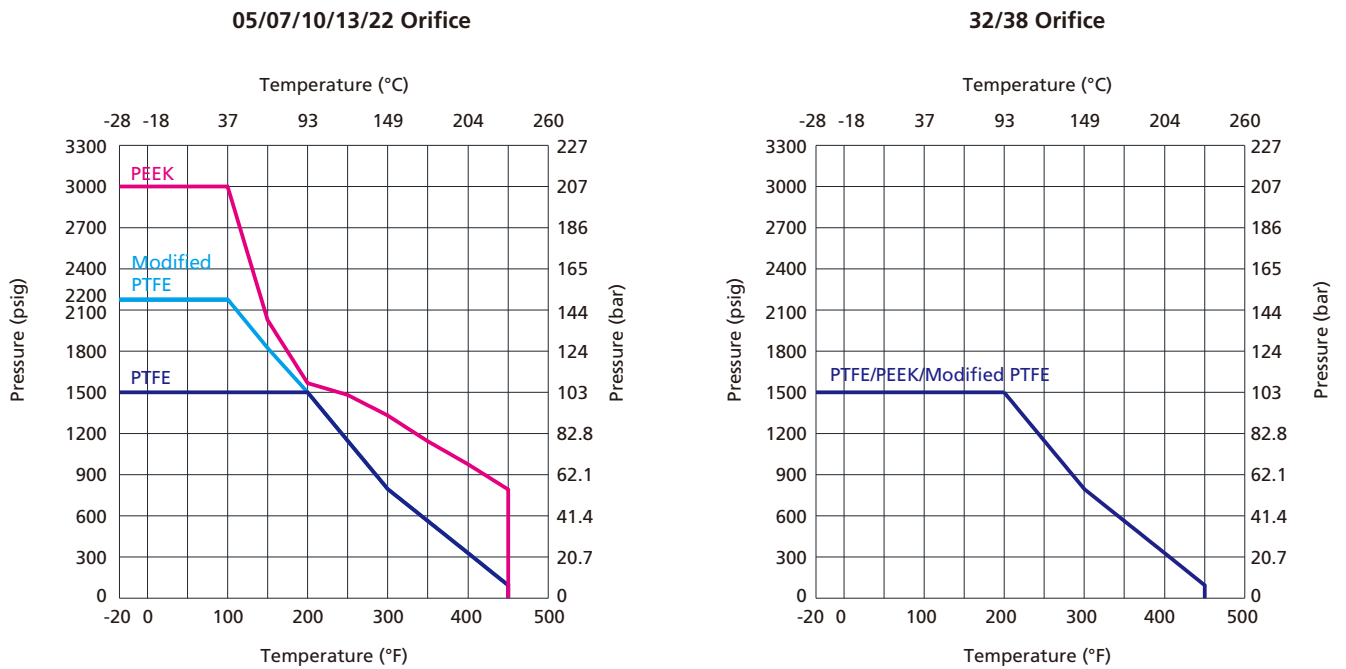

Notes:

1. The temperature and pressure rating is based on valves of standard materials.
2. Modified PTFE is a modified second generation polytetrafluoroethylene (TFM 1600), which is a PFA and PTFE composite. It has comparable chemical compatibility with PTFE, lower deformation rate than PTFE, and higher pressure and temperature tolerance than PTFE.

Working Pressure of the Weld End at -28 °C to 38 °C

Body Material	End Code	Size	Working Pressure (psig)
CF8M/CF3M	TB4	1/4" x 0.035"	5100
	TB6	3/8" x 0.035"	3300
	TB8	1/2" x 0.049"	3700
	TB12	3/4" x 0.065"	3300
	TB16	1" x 0.065"	2400
	TB24	1 1/2" x 0.065"	1600
	TB32	2" x 0.065"	1200

Note: BHP series high purity ball valves have a maximum working pressure of 3000 psig, which is also limited by the end connection.

Process Specification

Item	Process Specification	
	Special Cleaning and Packaging Process (FC-02)	Ultra High Purity Process (FC-03)
Material	CF8M, CF3M	CF3M
Flow Path Surface Roughness	Ra 25 µin. (0.6 µm)	Ra 10 µin. (0.25 µm)
Process	Machined	Electropolished
Lubrication	Components in contact with the medium are treated with special lubricants that are oxygen-compatible	

Fittings

Valves

Regulators

Filters

Tubing

Integrated Systems

Other Products

Technical Information

Major Materials of Construction

Fittings

Valves

Regulators

Filters

Tubing

Integrated Systems

Other Products

Technical Information

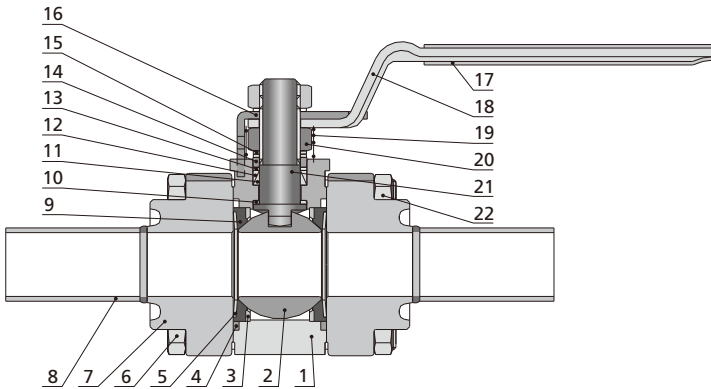

Item	Component	Material/Specification	
1	<i>Body</i>	<i>CF8M/A351</i>	<i>CF3M/A351</i>
2	<i>Ball</i>	<i>316 SS/A479</i>	<i>316L SS/A479</i>
3	<i>Support Ring</i>	<i>316 SS/A240</i>	<i>316L SS/A240</i>
4	<i>Side Seal</i>	<i>PTFE/D1710</i>	
5	<i>Butterfly Spring</i>	<i>Strain Hardened 316 SS/A240</i>	
6	Body Bolt	Gr.8M/A193	
7	<i>End Cap</i>	<i>CF8M/A351</i>	<i>CF3M/A351</i>
8	<i>Welded Tube</i>	<i>316L SS/A269</i>	
9	<i>Valve Seat</i>	<i>PTFE/Modified PTFE/PEEK</i>	
10	<i>Stem Bearing</i>	<i>PEEK</i>	
11	<i>Lower Packing</i>	<i>PTFE/D1710</i>	
12	<i>Upper Packing</i>	<i>PTFE/D1710</i>	
13	Packing Support	PEEK	
14	Seal Gland	PTFE-coated 316 SS/A479	
15	Stem Spring	Strain Hardened 316 SS/A240	
16	Stop Plate	304 SS/240	
17	Handle Cover	Vinyl Plastic	
18	Handle	304 SS/A240	
19	Grounding Spring	302 SS/A313	
20	Stem Nut	Gr.8M/A194	
21	<i>Stem</i>	<i>316 SS/A479</i>	<i>316L SS/A479</i>
22	Body Nut	Gr.8M/A194	

Note:

Components in contact with the media are listed in italics, for other materials of the valve please contact FITOK Group or authorized agent.

Dimensions

Dimensions in in. (mm) are for reference only and subject to change.

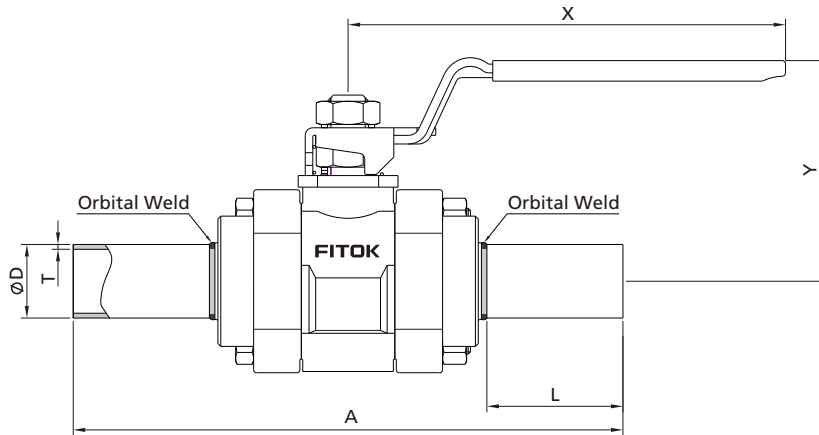

Ordering Information	Connection Type and Size	Orifice in. (mm)	Cv	Dimensions, in. (mm)					
				A	L	D	T	X	Y
BHP□□-TB4-05	1/4" × 0.035" Fractional Extended Tube Plain Butt Weld	0.18 (4.6)	1.1	3.54 (90)	0.79 (20)	0.25 (6.35)	0.035 (0.89)	2.37 (60.2)	1.66 (42.2)
BHP□□-FL4-05	1/4" FITOK Tube Fittings	0.19 (4.8)	1.2	3.17 (80.5)	—	—	—		
BHP□□-ML6-05	6 mm FITOK Tube Fittings		2.5	—	—	—	—		
BHP□□-ML8-05	8 mm FITOK Tube Fittings	0.28 (7.1)	3.8	3.54 (90)	0.79 (20)	0.375 (9.53)	0.035 (0.89)	2.37 (60.2)	1.66 (42.2)
BHP□□-TB6-07	3/8" × 0.035" Fractional Extended Tube Plain Butt Weld			3.17 (80.5)	—	—	—		
BHP□□-FL6-07	3/8" FITOK Tube Fittings			—	—	—	—		
BHP□□-ML10-07	10 mm FITOK Tube Fittings	3.20 (81.3)	—	—	—	—	—	—	—
BHP□□-TB8-10	1/2" × 0.049" Fractional Extended Tube Plain Butt Weld	0.40 (10.2)	7.2	4.72 (120)	1.18 (30)	0.50 (12.7)	0.049 (1.24)	4.50 (114)	2.35 (59.7)
BHP□□-FL8-10	1/2" FITOK Tube Fittings	0.41 (10.4)	7.5	4.04 (103.0)	—	—	—		
BHP□□-ML12-10	12 mm FITOK Tube Fittings			—	—	—	—		
BHP□□-FL12-13	3/4" FITOK Tube Fittings	0.52 (13.1)	13.6	4.04 (103)	—	—	—	4.50 (114)	2.35 (59.7)
BHP□□-ML16-13	16 mm FITOK Tube Fittings			—	—	—	—		
BHP□□-ML18-13	18 mm FITOK Tube Fittings			—	—	—	—		
BHP□□-TB12-22	3/4" × 0.065" Fractional Extended Tube Plain Butt Weld	0.62 (15.7)	18	5.12 (170)	1.42 (40)	0.75 (19.05)	0.065 (1.65)	6.00 (152)	2.94 (74.7)
BHP□□-TB16-22	1" × 0.065" Fractional Extended Tube Plain Butt Weld	0.87 (22.1)	36	6.3 (190)	1.97 (50)	1.00 (25.4)	0.065 (1.65)		
BHP□□-FL16-22	1" FITOK Tube Fittings	0.88 (22.2)	40	5.36 (136)	—	—	—		
BHP□□-FL20-22	1 1/4" FITOK Tube Fittings			6.34 (161)	—	—	—		
BHP□□-ML25-22	25 mm FITOK Tube Fittings			5.36 (136)	—	—	—		
BHP□□-ML28-22	28 mm FITOK Tube Fittings			6.14 (156)	—	—	—		
BHP□□-TB24-32	1 1/2" × 0.065" Fractional Extended Tube Plain Butt Weld	1.25 (31.8)	100	8.59 (218.2)	2.07 (52.6)	1.50 (38.1)	0.065 (1.65)	9.14 (232)	4.03 (102)
BHP□□-TB32-38	2" × 0.065" Fractional Extended Tube Plain Butt Weld	1.50 (38.1)	130	9.03 (229.3)	2.04 (51.8)	2.00 (50.8)	0.065 (1.65)		

- Sizes and types listed are standard. Other sizes and types are available upon request, please contact FITOK Group or our authorized distributors.
- Connection tube length can be specified, such as BHPSS-TB4-05, if L=30 mm is required, the part number should be changed to BHPSS-TB4 × L30-05.

Fittings
Valves
Regulators
Filters
Tubing
Integrated Systems
Other Products
Technical Information

Locking Device

- ⦿ Lock BHP series valves, locking hole diameters of the whole series of valves are 0.20 in. (5 mm)
- ⦿ To order a ball valve with locking device, please refer to the "Ordering Number Description" and add -L to the valve ordering number
Example: BHPSS-FL16-22-L

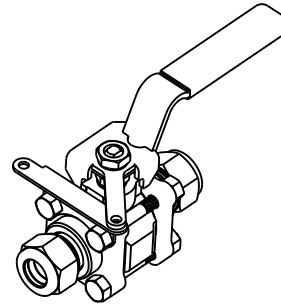

Low Dead Space Inserts

- ⦿ Reduce fluid entrapment around the ball, stem, and seat when the valve is open or closed
- ⦿ To order a ball valve with low dead space insert, please add -RZ to the valve ordering number
Example: BHPSS-FL4-05-RZ



Distribution Block Valves

BDP Series



Features

- Working temperature: -20 °F to 450 °F (-28 °C to 232 °C)
- Main line tube is full bore
- Main line Tube with orbital welding
- Branch ball valves are BHP or BGP series
- Factory tested for leaks with nitrogen or compressed air at rated working pressure, with optional helium leak testing to helium leak rate $\leq 1 \times 10^{-8}$ std-cm³/s

Pressure vs. Temperature

Branch ball valves are BHP Series

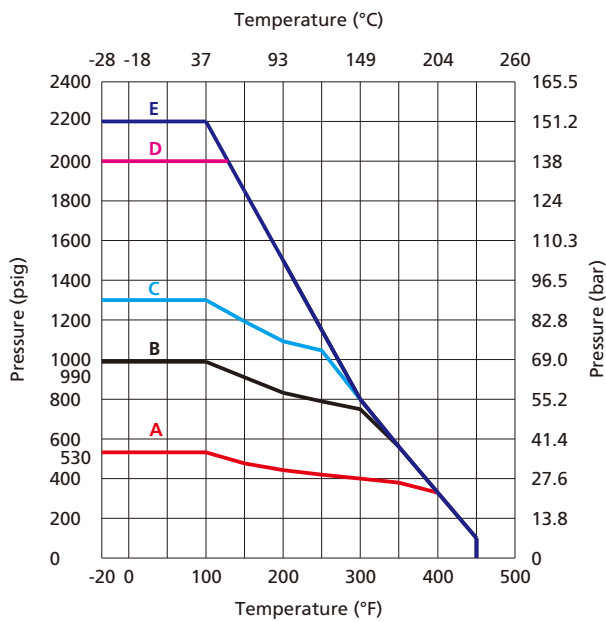

Branch ball valves are BGP Series

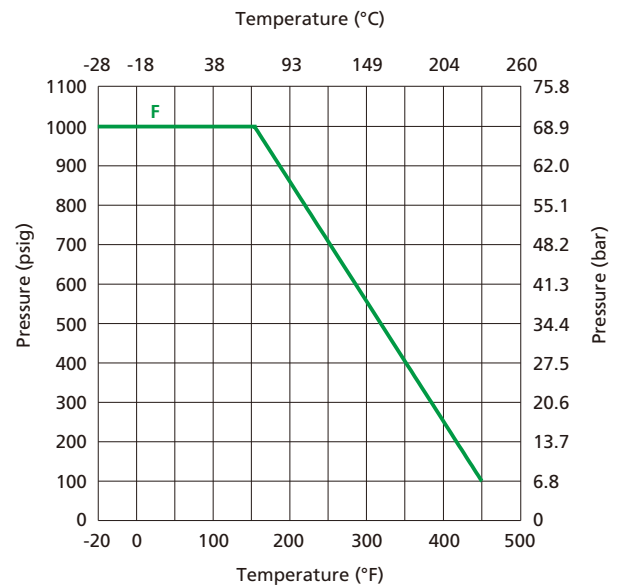

Main Line Tube Size in (mm)	4 × 0.083	2 × 0.065	1 1/2 × 0.065	1 × 0.065	3/4 × 0.065 1/2 × 0.049
Orifice Code	38, 32	13, 10	13, 10, 07	13, 10, 07	05, 07
Temperature and Pressure Curve	A —	B —	C —	D —	E —

Main Line Tube Size in (mm)	1 1/2 × 0.065	1 × 0.065	3/4 × 0.065 1/2 × 0.065
Orifice Code	15, 11, 07	15, 11, 07	07, 05
Temperature and Pressure Curve	F —		

Process Specification

Item \ Process Specification	Special Cleaning and Packaging Process (FC-02)	Ultra High Purity Process (FC-03)
Material	CF8M, CF3M	CF3M
Flow Path Surface Roughness	Ra 25 µin. (0.6 µm)	Ra 10 µin. (0.25 µm)
Process	Machined	Electropolished
Lubrication	Components in contact with the medium are treated with special lubricants that are oxygen-compatible	

Major Materials of Construction

Item	Component	Material/Specification		
1	Main Line Tube	316L SS/A269		
2	Valve block	316L SS/A479		
3	BHP Series Branch Ball Valve	Body	CF8M/A351	CF3M/A351
		Seat	Modified PTFE	
	BGP Series Branch Ball Valve	Body	CF8M/A351	CF3M/A351
		Seat	PTFE	

Note:
Components in contact with the media are listed in italics. Branch ball valves are BHP and BGP series, and other parts not listed are the same materials as BHP and BGP series standard valve parts.

Single Horizontal Cross

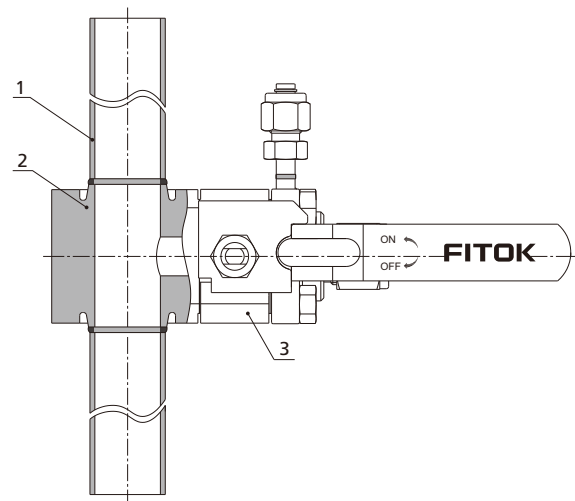

Double Horizontal Cross

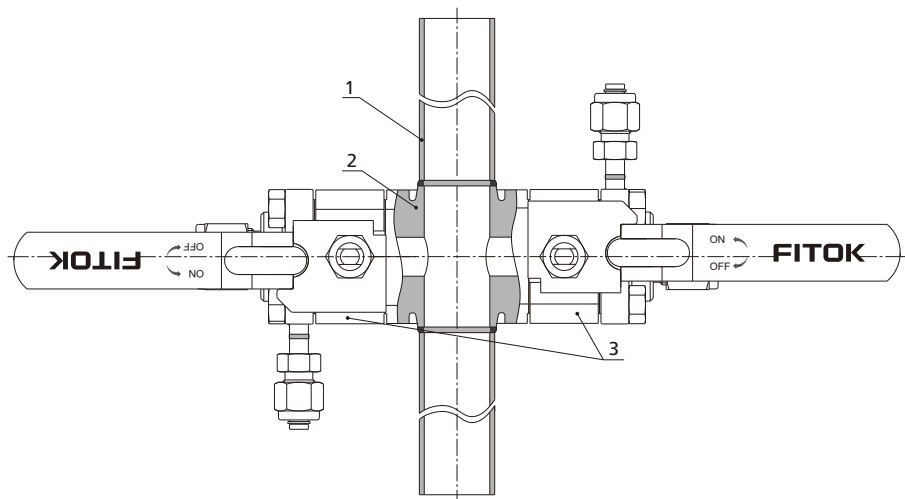

Fittings

Valves

Regulators

Filters

Tubing

Integrated Systems

Other Products

Technical Information

Ordering information and dimensions

Please refer to BHP and BGP series for the dimensions of branch ball valves.
 Dimensions are indicated in in. (mm, only for reference and subject to change).

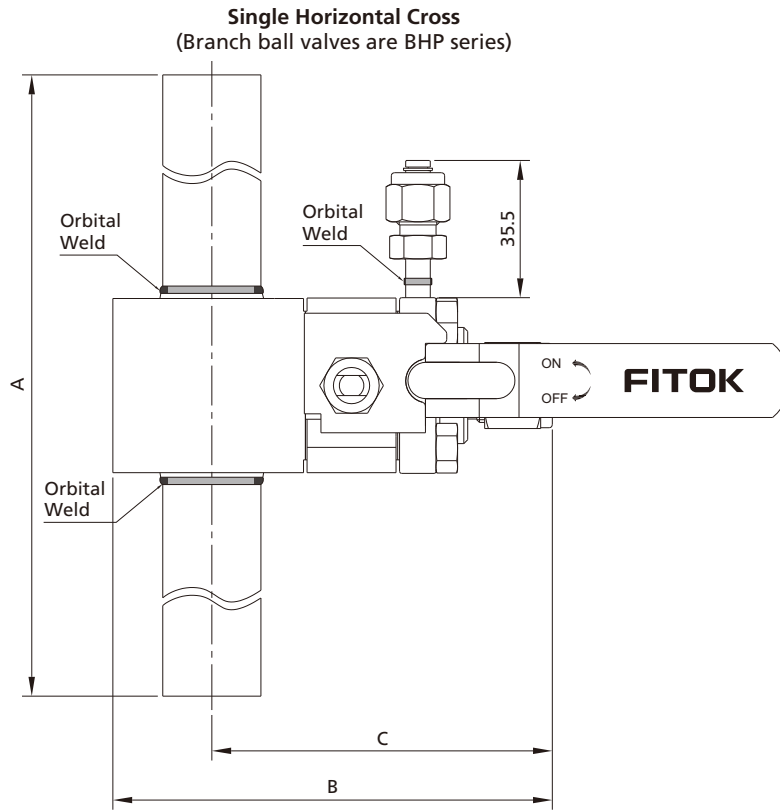

Ordering information	Main line tube size in.	Branch line tube end size	Orifice in. (mm)	Dimensions, in. (mm)		
				A	B	C
BDP□□-SHC-TB8-FL4-05-D1	1/2 × 0.049	1/4 in.	0.187 (4.8)	7.00 (178)	3.31 (84.1)	2.56 (65.0)
BDP□□-SHC-TB8-FL6-07-D1		3/8 in.	0.281 (7.1)			
BDP□□-SHC-TB12-FL4-05-D1	3/4 × 0.065	1/4 in.	0.187 (4.8)	9.00 (229)	3.31 (84.1)	2.56 (65.0)
BDP□□-SHC-TB12-FL6-07-D1		3/8 in.	0.281 (7.1)			
BDP□□-SHC-TB16-FL6-07-D1	1 × 0.065	3/8 in.	0.281 (7.1)	13.0 (330)	4.31 (109)	3.31 (84.1)
BDP□□-SHC-TB16-FL8-10-D1		1/2 in.	0.411 (10.4)		4.44 (113)	3.44 (87.4)
BDP□□-SHC-TB16-FL12-13-D1		3/4 in.	0.516 (13.1)			
BDP□□-SHC-TB24-FL6-07-D1	1 1/2 × 0.065	3/8 in.	0.281 (7.1)	13.0 (330)	4.56 (116)	3.44 (87.4)
BDP□□-SHC-TB24-FL8-10-D1		1/2 in.	0.411 (10.4)		4.69 (119)	6.56 (90.4)
BDP□□-SHC-TB24-FL12-13-D1		3/4 in.	0.516 (13.1)			
BDP□□-SHC-TB32-FL8-10-D1	2 × 0.065	1/2 in.	0.411 (10.4)	13.0 (330)	5.97 (152)	4.06 (103)
BDP□□-SHC-TB32-FL12-13-D1		3/4 in.	0.516 (13.1)			
BDP□□-SHC-TB64-FL24-32-D1	4 × 0.083	1 1/2 in.	1.250 (31.8)	23.0 (584)	10.2 (259)	7.19 (183)
BDP□□-SHC-TB64-FL32-38-D1		2 in.	1.500 (38.1)		11.6 (295)	8.63 (219)

Single Horizontal Cross
(Branch ball valves are BGP series)

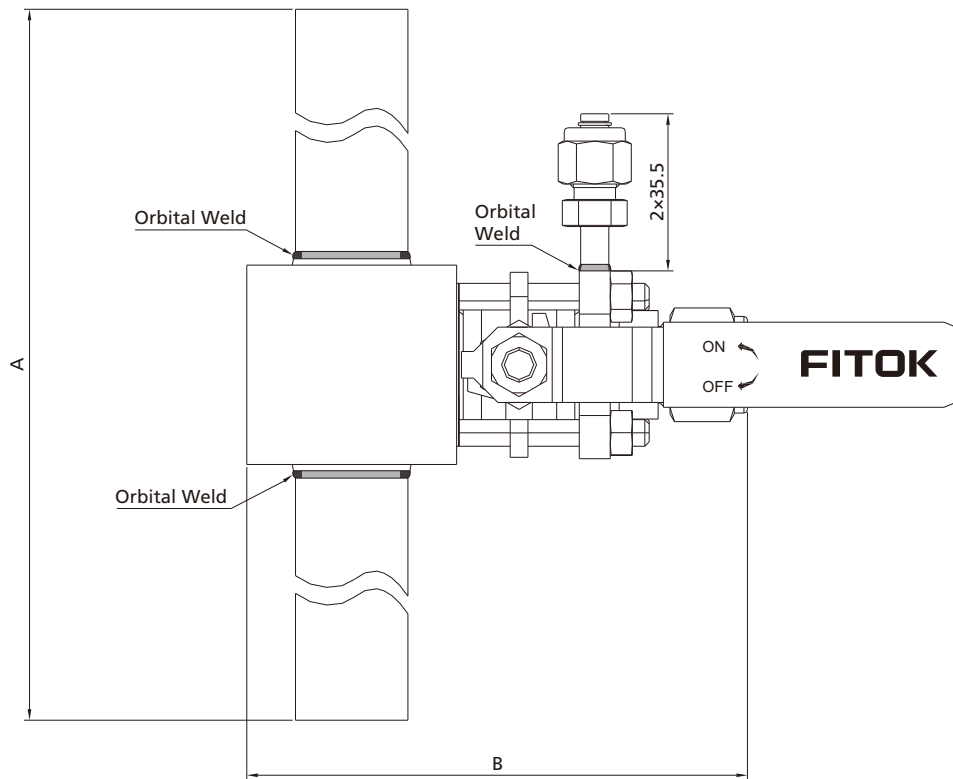

Ordering information	Main line tube size in.	Branch line tube end size	Orifice in. (mm)	Dimensions, in. (mm)	
				A	B
BDP□□-SHC-TB8-BGP-FL4-05-D1	1/2 × 0.049	1/4 in.	0.19 (4.8)	7.00 (178)	3.12 (79.2)
BDP□□-SHC-TB8-BGP-FL6-07-D1		3/8 in.	0.28 (7.1)		
BDP□□-SHC-TB12-BGP-FL4-05-D1	3/4 × 0.065	1/4 in.	0.19 (4.8)	9.00 (229)	3.12 (79.2)
BDP□□-SHC-TB12-BGP-FL6-07-D1		3/8 in.	0.28 (7.1)		
BDP□□-SHC-TB16-BGP-FL6-07-D1	1 × 0.065	3/8 in.	0.28 (7.1)	13.0 (330)	4.53 (115)
BDP□□-SHC-TB16-BGP-FL8-11-D1		1/2 in.	0.42 (10.6)		4.72 (120)
BDP□□-SHC-TB16-BGP-FL12-15-D1		3/4 in.	0.55 (14.0)		
BDP□□-SHC-TB24-BGP-FL6-07-D1	1 1/2 × 0.065	3/8 in.	0.28 (7.1)	13.0 (330)	4.80 (122)
BDP□□-SHC-TB24-BGP-FL8-11-D1		1/2 in.	0.42 (10.6)		5.00 (127)
BDP□□-SHC-TB24-BGP-FL12-15-D1		3/4 in.	0.55 (14.0)		

Fittings

Valves

Regulators

Filters

Tubing

Integrated Systems

Other Products

Technical Information

Double Horizontal Cross
(Branch ball valves are BHP series)

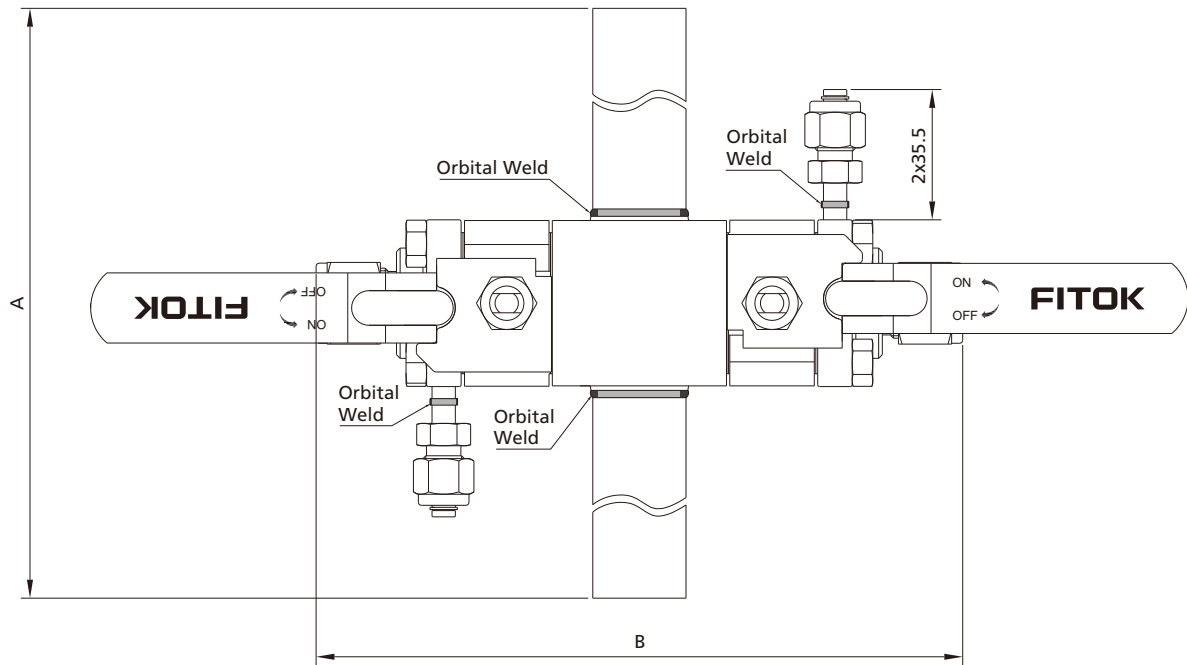

Ordering information	Main line tube size in.	Branch line tube end size	Orifice in. (mm)	Dimensions, in. (mm)	
				A	B
BDP□□-DHC-TB8-FL4-05-D1	1/2 × 0.049	1/4 in.	0.187 (4.8)	7.00 (178)	5.19 (132)
BDP□□-DHC-TB8-FL6-07-D1		3/8 in.	0.281 (7.1)		
BDP□□-DHC-TB12-FL4-05-D1	3/4 × 0.065	1/4 in.	0.187 (4.8)	9.00 (229)	5.19 (132)
BDP□□-DHC-TB12-FL6-07-D1		3/8 in.	0.281 (7.1)		
BDP□□-DHC-TB16-FL6-07-D1	1 × 0.065	3/8 in.	0.281 (7.1)	13.0 (330)	6.69 (170)
BDP□□-DHC-TB16-FL8-10-D1		1/2 in.	0.411 (10.4)		6.88 (175)
BDP□□-DHC-TB16-FL12-13-D1		3/4 in.	0.516 (13.1)		
BDP□□-DHC-TB24-FL6-07-D1	1 1/2 × 0.065	3/8 in.	0.281 (7.1)	13.0 (330)	6.94 (176)
BDP□□-DHC-TB24-FL8-10-D1		1/2 in.	0.411 (10.4)		7.13 (181)
BDP□□-DHC-TB24-FL12-13-D1		3/4 in.	0.516 (13.1)		
BDP□□-DHC-TB32-FL8-10-D1	2 × 0.065	1/2 in.	0.411 (10.4)	13.0 (330)	8.19 (208)
BDP□□-DHC-TB32-FL12-13-D1		3/4 in.	0.516 (13.1)		
BDP□□-DHC-TB64-FL24-32-D1	4 × 0.083	1 1/2 in.	1.250 (31.8)	23.0 (584)	14.4 (365)
BDP□□-DHC-TB64-FL32-38-D1		2 in.	1.500 (38.1)		17.2 (437)

Double Horizontal Cross
(Branch ball valves are BGP series)

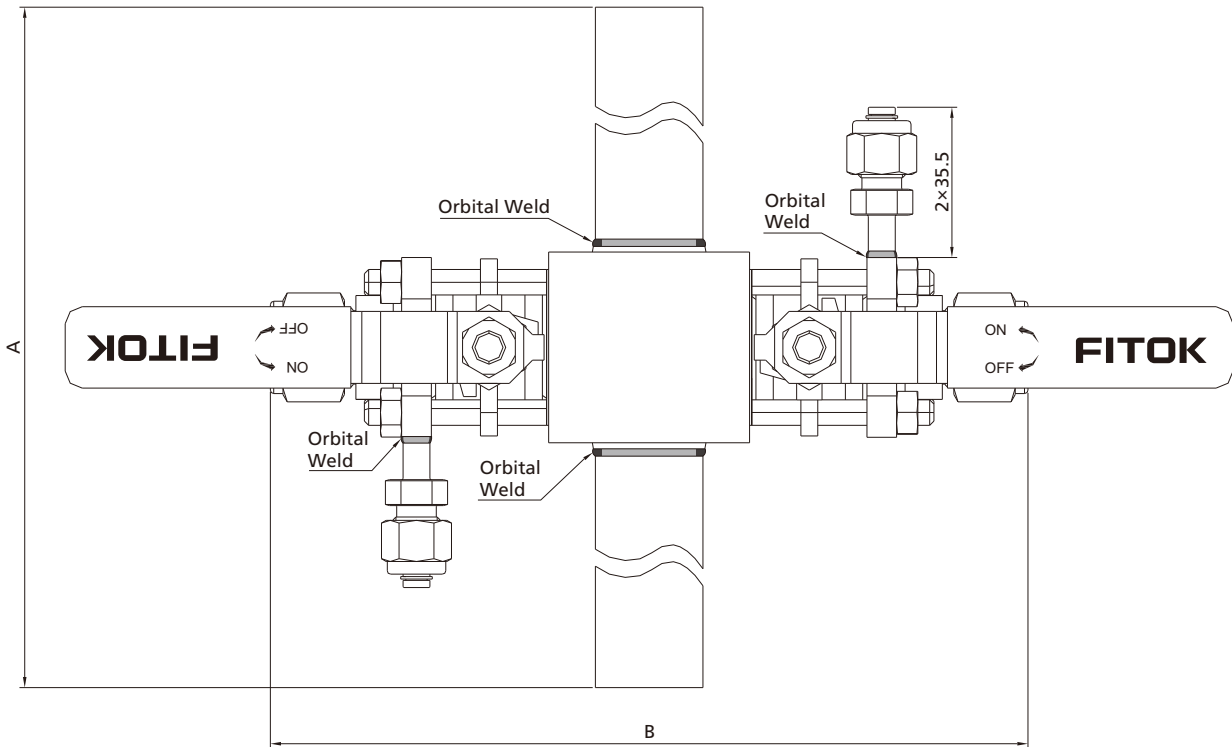

Ordering information	Main line tube size in.	Branch line tube end size	Orifice in. (mm)	Dimensions, in. (mm)	
				A	B
BDP□□-DHC-TB8-BGP-FL4-05-D1	1/2 × 0.049	1/4 in.	0.19 (4.8)	7.00 (178)	4.65 (118)
BDP□□-DHC-TB8-BGP-FL6-07-D1		3/8 in.	0.28 (7.1)		
BDP□□-DHC-TB12-BGP-FL4-05-D1	3/4 × 0.065	1/4 in.	0.19 (4.8)	9.00 (229)	4.65 (118)
BDP□□-DHC-TB12-BGP-FL6-07-D1		3/8 in.	0.28 (7.1)		
BDP□□-DHC-TB16-BGP-FL6-07-D1	1 × 0.065	3/8 in.	0.28 (7.1)	13.0 (330)	6.14 (156)
BDP□□-DHC-TB16-BGP-FL8-11-D1		1/2 in.	0.42 (10.6)		6.34 (161)
BDP□□-DHC-TB16-BGP-FL12-15-D1		3/4 in.	0.55 (14.0)		
BDP□□-DHC-TB24-BGP-FL6-07-D1	1 1/2 × 0.065	3/8 in.	0.28 (7.1)	13.0 (330)	6.38 (162)
BDP□□-DHC-TB24-BGP-FL8-11-D1		1/2 in.	0.42 (10.6)		6.57 (167)
BDP□□-DHC-TB24-BGP-FL12-15-D1		3/4 in.	0.55 (14.0)		

Fittings

Valves

Regulators

Filters

Tubing

Integrated Systems

Other Products

Technical Information

Ordering Number Description

BDPSS - SHC - TB24 - BGP - FL8 - 13 - I - D1 - AR2F3

Fittings
Valves
Regulators
Filters
Tubing
Integrated Systems
Other Products
Technical Information

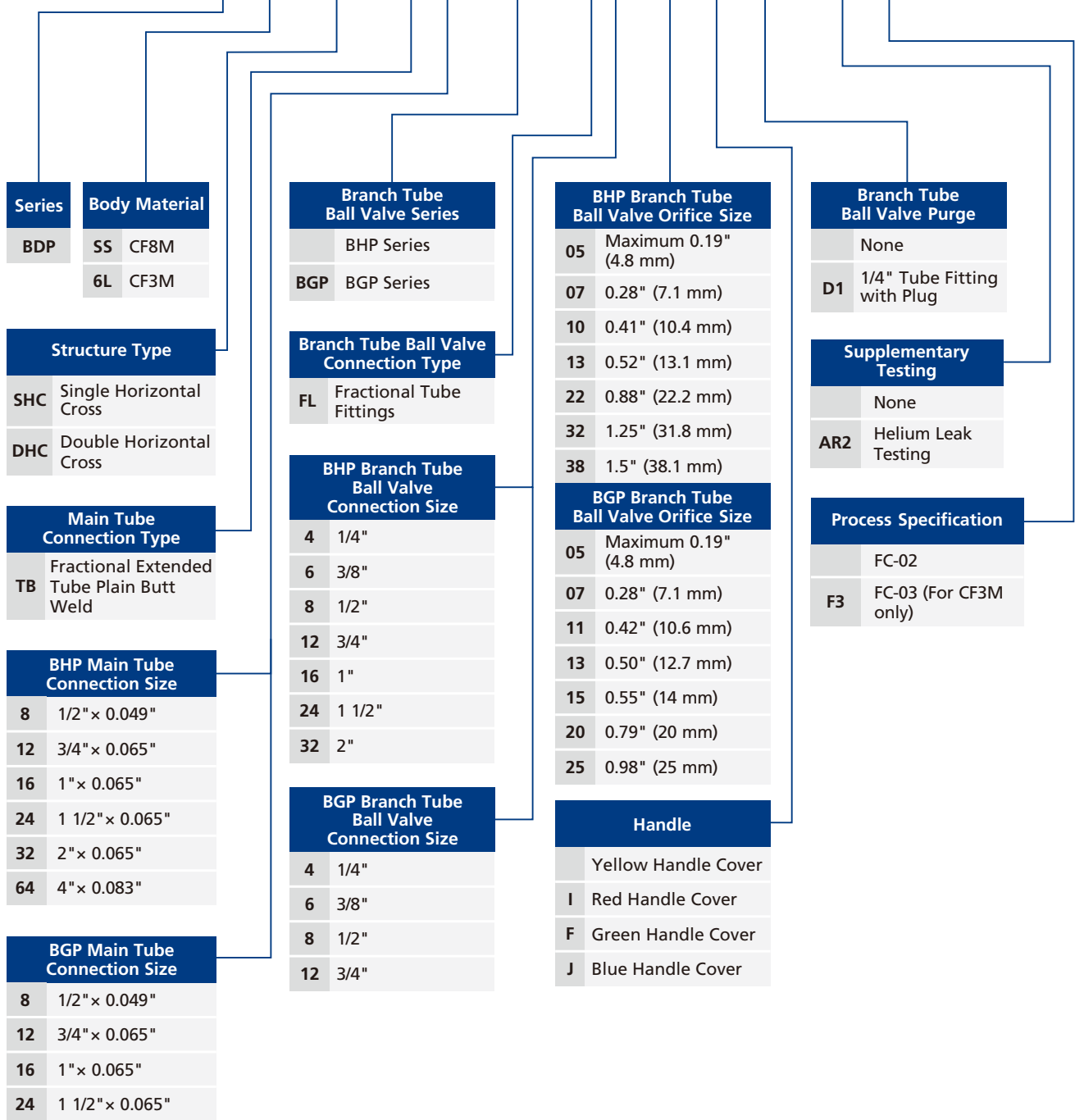

Note: "Ordering Number Description" is a reference to understand the combination rules of FITOK product part number. Not all combinations are available, Should you have any questions, please contact FITOK Group or our authorized distributors.

Hex Bar Stock High Purity Ball Valves

BRP Series

Introduction

BRP series hex bar high purity ball valves are designed to meet the requirements of degreasing, low working pressure and bi-directional flow for the clean dry air (CDA) and bulk gas distribution line, which are widely used in specialty gas, semiconductor and chemical industries.



Features

- Working pressure up to: 2000 psig (138 bar)
- Working temperature: -65 °F to 400 °F (-54 °C to 204 °C)
- Orifice sizes: 0.19" (4.8 mm) to 0.63" (16 mm)
- Factory tested for leaks with nitrogen or compressed air at rated working pressure, with optional helium leak testing to helium leak rate $\leq 1 \times 10^{-8}$ std-cm³/s

Pressure vs. Temperature

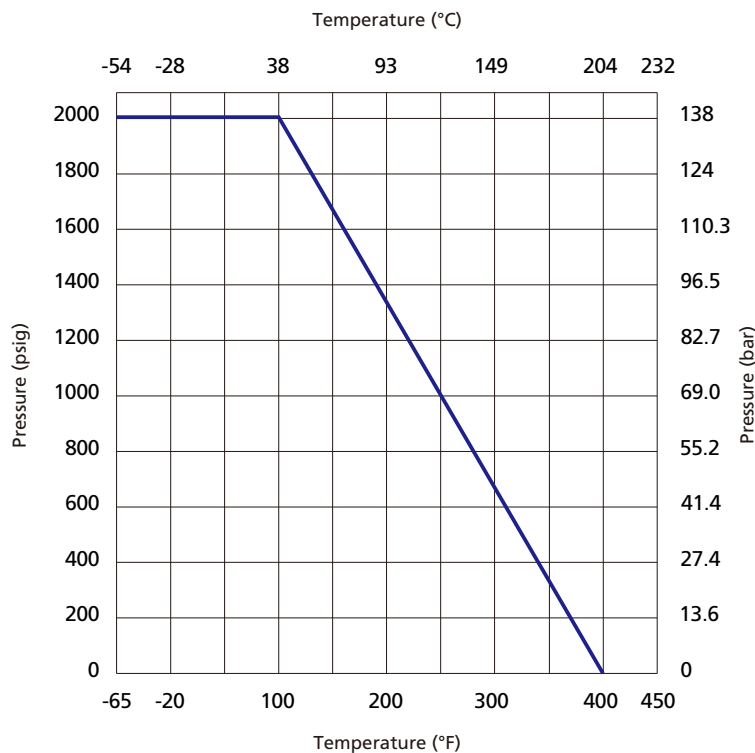

Note: The temperature and pressure rating is based on valves of standard materials.

Fittings

Valves

Regulators

Filters

Tubing

Integrated Systems

Other Products

Technical Information

Process Specification

Item	Special Cleaning and Packaging Process (FC-02)	Ultra High Purity Process (FC-03)
Material	316 SS, 316L SS	316L SS
Flow Path Surface Roughness	Ra 25 µin. (0.6 µm)	Ra 10 µin. (0.25 µm)
Process	Machined	Electropolished
Lubrication	Components in contact with the medium are treated with special lubricants that are oxygen- compatible	

Major Materials of Construction

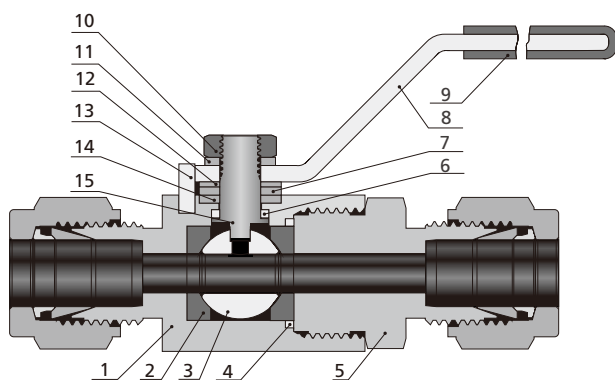

Handle Options

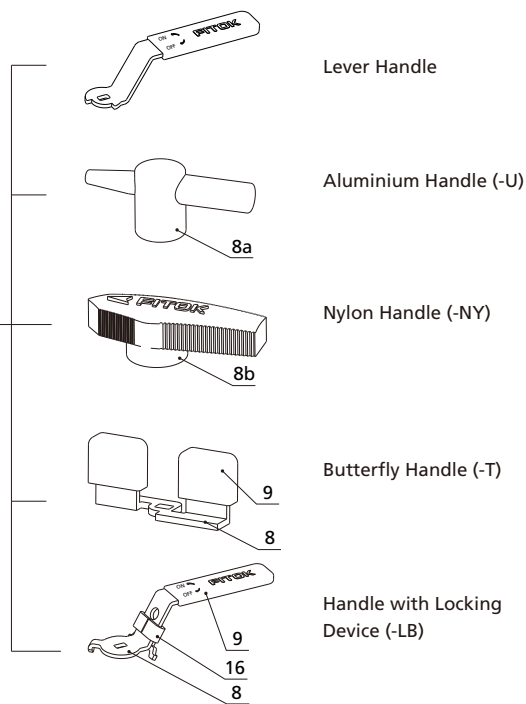

Item	Component	Material/Specification	
		316 SS	316L SS
1	<i>Body</i>	<i>316 SS/A479</i>	<i>316L SS/A479</i>
2	<i>Seat</i>	<i>PFA/D3307</i>	
3	<i>Ball</i>	<i>316 SS/A479</i>	<i>316L SS/A479</i>
4	<i>Gasket</i>	<i>316L SS/A269</i>	
5	<i>End Connection</i>	<i>316 SS/A479</i>	<i>316L SS/A479</i>
6	<i>Lower Packing</i>	<i>Modified PTFE</i>	
7	Washer	316 SS/A479	
8	Handle	304 SS/A240	
8a		Aluminium	
8b		Nylon with 304 SS insert	
9	Sleeve	Vinyl Ester	
10	Stem Nut	Stainless Steel	
11	Gasket	Stainless Steel	
12	Coned-Disc Spring	S17700/A693	
13	Stop Pin ^①	Stainless Steel	
14	<i>Upper Packing</i>	<i>Modified PTFE</i>	
15	<i>Stem</i>	<i>316 SS/A479</i>	<i>316L SS/A479</i>
16	Lock Block	304 SS/A240	

Note: Components in contact with the media are listed in italics.
For other materials, please contact FITOK Group or our authorized distributors.

① A handle with a locking device does not include a stop pin.

Dimensions

Dimensions in in. (mm) are for reference only and subject to change.

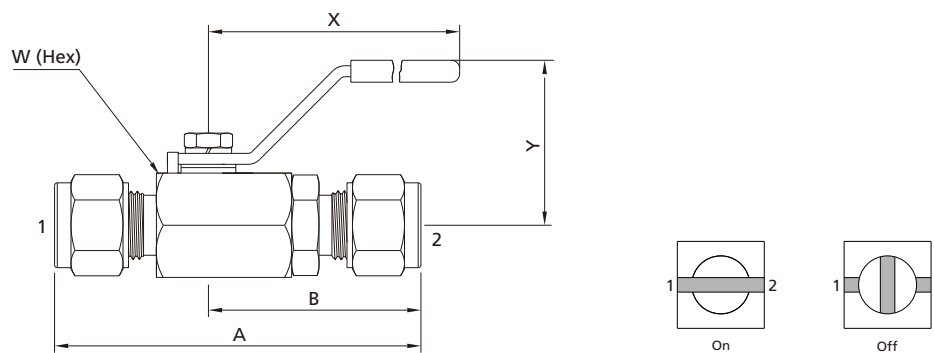

Fittings

Valves

Regulators

Filters

Tubing

Integrated Systems

Other Products

Technical Information

Basic Ordering Number	Connection Type and Size	Orifice in. (mm)	Cv	Dimensions, in. (mm)				
	Connection 1/2			A	B	W	X	Y
BRP□□-ML6-05	6 mm FITOK	0.19 (4.8)	1.25	2.57 (65.2)	1.50 (38.1)	3/4 (19.05)	2.36 (60.0)	1.18 (30)
BRP□□-ML8-05	8 mm FITOK			2.63 (66.8)	1.53 (38.8)			
BRP□□-FL4-05	1/4" FITOK			2.57 (65.2)	1.50 (38.1)			
BRP□□-FL5-05	5/16" FITOK			2.63 (66.8)	1.53 (38.8)			
BRP□□-ML10-07	10 mm FITOK	0.28 (7.1)	2.50	2.87 (72.9)	1.68 (42.7)	7/8 (22.23)		1.26 (32)
BRP□□-FL6-07	3/8" FITOK							
BRP□□-ML12-10	12 mm FITOK	0.35 (8.9)	5.30	3.15 (80.0)	1.83 (46.5)	1 1/16 (27.0)	3.15 (80)	1.54 (39)
BRP□□-ML14-10	14 mm FITOK			3.24 (82.2)	1.87 (47.5)			
BRP□□-FL8-10	1/2" FITOK			3.15 (80.0)	1.83 (46.5)			
BRP□□-FL10-10	5/8" FITOK			3.24 (82.2)	1.87 (47.5)			
BRP□□-ML16-13	16 mm FITOK	0.47 (12.0)	8.60	3.50 (88.9)	2.00 (50.8)	1 1/4 (31.75)	3.94 (100)	2.03 (51.7)
BRP□□-ML18-13	18 mm FITOK							
BRP□□-FL12-13	3/4" FITOK							
BRP□□-ML22-16	22 mm FITOK	0.63 (16.0)	17.35	3.96 (100.6)	2.24 (56.8)	1 1/2 (38.1)		2.15 (54.8)
BRP□□-ML25-16	25 mm FITOK			4.31 (109.5)	2.42 (61.5)			
BRP□□-FL16-16	1" FITOK							

1. FITOK means FITOK double ferrule tube fittings.
2. Sizes and types listed are standard. Other sizes and types are available upon request, please contact FITOK Group or our authorized distributors.
3. Dimensions are shown with FITOK tube fitting nuts finger-tightened. All dimensions are for reference only and are subject to change. For dimensions not shown above, please contact FITOK Group or our authorized distributors.

O-Ring Stem Packing Ball Valves

- ☉ Suitable for applications where adjusting the packing during valve operation is inconvenient.
- ☉ Standard factory testing includes a sealing test using nitrogen or compressed air at rated working pressure. Optional helium leak testing is available, with a helium leakage rate $\leq 1 \times 10^{-6}$ std-cm³/s

Materials of Construction

Item	Component	Material/Specification
1	<i>O-ring</i>	<i>Fluorocarbon FKM, EPDM, Buna N, FFKM</i>
2	<i>Lower Packing</i>	<i>PEEK</i>
3	Seal	PTFE

Note: Wetted components are listed in italics. Other components are consistent with standard materials of construction.

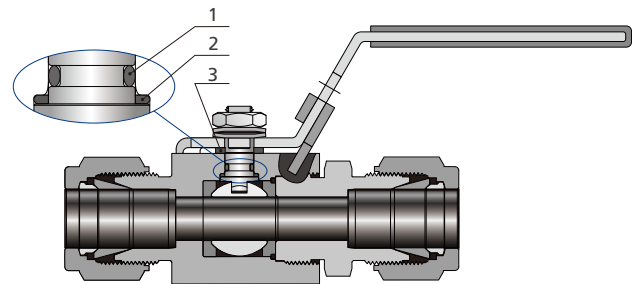

Temperature Range

Stem Packing Material	Designator	Temperature Range °F (°C)
<i>Fluorocarbon FKM</i>	VI	5 ~ 400 (-15 ~ 204)
<i>EPDM</i>	E	-40 ~ 250 (-40 ~ 121)
<i>Buna N</i>	B	0 ~ 250 (-17 ~ 121)
<i>FFKM</i>	Z	14 ~ 400 (-10 ~ 204)

Ordering Information

- ☉ To order an O-ring stem packing ball valve, add the suffix VI to the standard part number.
Example: BRPSS-ML12-10VI

Locking Device

Body Material	Orifice	Locking Hole Diameter in. (mm)	Example
A variety of optional materials (bar stock)	05	0.19 (4.8)	BRPSS-ML12-10-LB
	07		
	10		
	13	0.24 (6.2)	
	16		

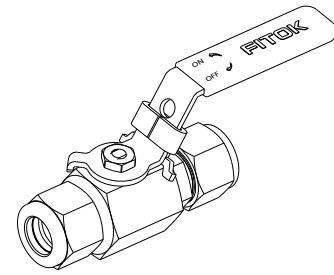

Locking Device

Ordering Number Description

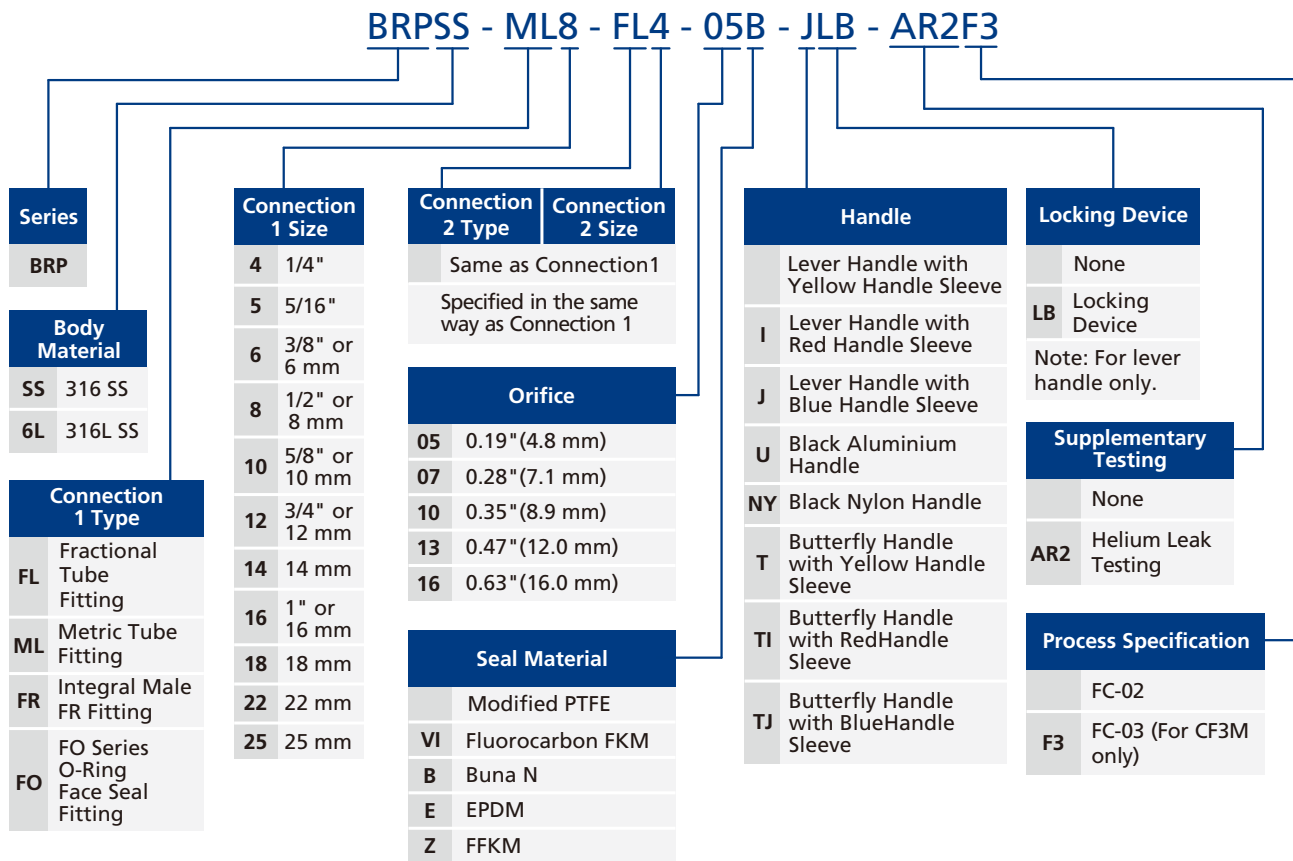

Note: "Ordering Number Description" is a reference to understand the combination rules of FITOK product part number. Not all combinations are available, Should you have any questions, please contact FITOK Group or our authorized distributors.

Fittings
Valves
Regulators
Filters
Tubing
Integrated Systems
Other Products
Technical Information